



## LIGHTNING RODS

### 385 0006/385 0007

### GM • CHRYSLER • FORD

### A P P L I C A T I O N S

## ! WARNING

Vehicles that have steering column lock — refer to separate instruction sheet that is titled "Safety Ignition Block." This sheet and this device are included with this kit and must be installed to prevent the possibility of turning the ignition switch off while vehicle is in motion. The steering column will lock when this switch is turned off. Failure to heed this warning could result in accidental steering lock-up while vehicle is in motion.

### EXCEPTION

GM cars equipped with factory floor shift. Safety ignition block device explained under "Warning" on this page, is not used on GM cars that are equipped with factory floorshift. Retain stock steering column lock activating linkage. Retain stock transmission arm. Remove stock shifter and linkage to transmission only.

### ALL OTHER APPLICATIONS

Remove all stock linkage between steering column and transmission. Remove transmission control lever from steering column. The lever at the lower end of the steering column just ahead of the firewall. **MUST** be secured at the extreme end of its travel **UPWARD**. Use wire to tie it up in this position. REFER TO SEPARATE SHEET OF INSTRUCTIONS "SAFETY IGNITION BLOCK".

### SHIFTER INSTALLATION

Adjust seat to normal driving position. Determine best location for shifter. Hold shifter in this position on floor and use mounting holes in shifter frame as guides to drill four 1/8" diameter holes through floor.

Punch mark floor at point where cable will enter through floor. Cut a 3/4" diameter hole. Remove burrs from hole.

Install neutral safety switch on shifter. Refer to detail drawing on exploded assembly drawing "install neutral safety switch".

Disconnect the stock neutral safety switch wires from terminals on stock switch. Connect these wires to the terminals on the neutral safety switch on the Hurst shifter. Distance from original stock switch may require additional wire.

Fasten shifter and console bracket to floor with sheet metal screws and flatwashers. Fasten front of shifter. (Refer to exploded assembly drawing)

### CAUTION

**AVOID SHARP BENDING OF CABLE. CABLE WILL BE PERMANENTLY DAMAGED BY ANY SHARP BENDING.**

Pass cable up through 3/4" diameter hole in floor. Mark the cable housing where it passes through floor. Wrap the cable generously at the mark with friction tape or plastic tape. Install cable. Fasten cable housing to the shifter frame with clamp. Hammer clamp until it is seated against ferrule.

Fasten end of cable to stud on shifter cable arm with cotter pin. Refer to detail drawing.

**INSTALL REVERSE LOCK-OUT ASSEMBLY ON SHIFTER.** Refer to detail drawing on exploded assembly drawing. Insert pivot sleeve in shifter frame. Use finger to keep sleeve flush in hole in shifter frame and slide lock-out lever over protruding end of pivot sleeve. Install screw, flatwashers and self-locking hex-nut. This assembly is to be as tight as possible without binding. Lever **MUST** rotate freely on pivot sleeve. Attach extension spring between shifter frame and lever as shown in drawing.

Remove stock transmission arm. Refer to drawings on page to identify the arm that fits your transmission. Assemble the cable pin in that arm with hex-nut but do not tighten at this time. Install arm on transmission control shaft.

### EXCEPTION—FORD TRANSMISSIONS

Refer to drawing — "FORD TRANSMISSIONS ONLY". Rotate stock arm to "N" (Neutral) position. Use a center punch to make a mark on arm and a corresponding mark on boss of transmission case. The part of the arm that is shaded in the drawing must be removed by grinding. Assemble the cable pin in the arm with hex-nut but do not tighten at this time. Install arm on transmission but do not fasten clamp bolt until you have progressed to paragraph TITLED, "NEUTRAL ALIGNMENT".

Install cable bracket on transmission. Refer to directions with the drawing of your installation on page 3.

Carefully route the cable around toward the cable bracket and fasten cable in bracket with cable clamp. Hammer clamp in until it is seated against ferrule.

Locate cable hanger approximately at the middle of the loop. Drill a 1/4" diameter hole up through floor for cable hanger. Fold clamp around cable, push split end through hole in floor. Push pointed end through split end (inside drilled hole), apply force until joint snaps together and locks itself in the drilled hole.

Remove the buttons from knobs. Remove knobs (buttons and knobs are both threaded). Slide rubber sleeves onto 2-1 stick and D-2 stick. Place the shorter dust cover on the D-2 stick, the longer one on the 2-1 stick. Replace knobs and buttons.

### INSTALL CONSOLE

Refer to drawings on page 4. Place console plate in position on top of console. Spot drill three 7/32" diameter holes through plastic

console. Drill a 7/32" diameter hole at front end of console for console clip. Install speed nut on console clip.

Refer to drawing titled: "drilling holes in console". Place console plate in position on top of console. Spot drill three 7/32" diameter holes through plastic console. Refer to drawing titled: drill hole in front of console". Drill 7/32" diameter hole at front end of console for console clip. Install speed nut on console clip.

Install speed nuts on rear bracket of shifter. Fasten rear end of console to bracket with #10-24 x 1 socket head cap screws (item 27).

Refer to drawing "Install console clip". Mark carpet along front edge of console with chalk. Also mark a line on carpet to indicate the centerline of the mounting screw. Remove the console.

Drill a 1/8" diameter hole through floor as indicated in drawing. Fasten the console clip to the floor with a 1/4 x 1 sheet metal screw (Item 3) and flatwasher (item 4).

Locate the proper positioning for the shift pattern indicator by placing it on the console and then placing the console plate over it. Note position before removing backing strip from pressure sensitive adhesive side of indicator label. Apply indicator label to console.

### NEUTRAL ALIGNMENT

Shifter sticks and transmission arm **MUST** be at Neutral positions. Refer to the drawings of the shifting patterns. The pattern labeled "neutral alignment" shows the correct positions of the sticks. Press the button on stick No. 3 and rotate the cable arm on shifter until the button can be depressed and the stick can be moved to its Neutral position. Repeat this procedure on stick No. 2 and then on stick No. 1. Shifter sticks and cable are now at correct positions. Rotate the transmission control arm through its full travel to determine N (Neutral) position. Refer to the drawing that shows detenting (standard pattern and reversed valve body pattern).

### IMPORTANT

Cable pin must be free to slide in the slot in the transmission control arm—(hex-nut on pin **MUST BE LOOSE**).

Attach the cable end to the cable pin that is assembled in the slot in the transmission control arm. Fasten with cotter pin.

Tighten hex-nut on cable pin in transmission control arm. Be careful to avoid disturbing the position the cable pin located by the cable end. Test operation of shifter.

Attach front end of console plate to console with screw (item 21) and speed nut (item 22—underneath console). Do not tighten. Swing plate out of the way. Install console. Swing console plate into installed position, and fasten attaching screws—(four-item 21). Push indicator pointer onto bayonet on lever (through pointer slot).

# CONTENTS OF KIT

- |                                       |                  |
|---------------------------------------|------------------|
| 1. SHIFTER ASSEMBLY—(GM APPLICA.)     | PT. 385 0010     |
| SHIFTER ASSEMBLY—(CHRYSLER-FORD)      | PT. 385 0011     |
| 2. CONSOLE BRACKET                    | PT. 117 0176     |
| 3. 1/4" X 1 HEX-HD. SELF-TAPPING SCW. | PT. 272 5699 (5) |
| 4. 1/4" FLATWASHER                    | PT. 267 3478 (5) |
| 5. NEUTRAL SAFETY SWITCH              | PT. 248 7846     |
| REVERSE LOCK-OUT ASSEMBLY—            |                  |
| 6. PIVOT SLEEVE                       | PT. 224 0036     |
| 7. LEVER                              | PT. 175 0006     |
| 8. #10 FLATWASHER                     | PT. 267 7150 (2) |
| 9. SCREW                              | PT. 271 2594     |
| 10. HEX-NUT—SELF-LOCKING              | PT. 179 0018     |
| 11. SPRING—EXTENSION                  | PT. 230 0062     |
| 12. RUBBER SLEEVE                     | PT. 224 0024 (2) |
| 13. DUST COVER—2—1 STICK              | PT. 130 0034     |
| 14. DUST COVER—D—2 STICK              | PT. 130 0033     |
| 15. CONSOLE                           | PT. 129 0010     |
| 16. CONSOLE CLIP                      | PT. 127 0013     |
| 17. SPEED NUT (#10—24)                | PT. 179 0045 (4) |
| 18. PATTERN INDICATOR—STND. PAT.      | PT. 241 0008     |
| PATTERN INDICATOR—REV. PAT.           | PT. 241 0012     |
| 19. CONSOLE PLATE                     | PT. 195 0180     |
| 20. #10—24 X 5/8 SOCKET-HD. CAP SCW.  | PT. 215 0036 (4) |
| 21. POINTER—INDICATOR                 | PT. 198 0001     |
| 22. CABLE                             | PT. 120 5721     |
| 23. CABLE CLIP                        | PT. 127 5702 (2) |
| 24. CABLE HANGER                      | PT. 126 0013     |
| 25. CABLE PIN (FIT ALL TRANS. ARMS)   | PT. 189 0011     |
| 26. 3/8—16 HEX-NUT—SELF-LOCKING       | PT. 179 5959     |
| 27. COTTER PIN                        | PT. 190 3539 (2) |

BAGGED HARDWARE PACKAGE—PT. 154 0169

**INSTALL NEUTRAL SAFETY SWITCH**  
—SEE TEXT

**INSTALL REVERSE LOCK-OUT**

REFER TO DRAWINGS AND DIRECTIONS ON PAGE 3 FOR IDENTITY AND USE OF FOLLOWING PARTS.

385 0006 INSTALLATION  
GM 350, 400 & 200 (METRIC) TURBO-HYDRAMATIC INSTALLATIONS

- |                                       |              |
|---------------------------------------|--------------|
| 28. BRACKET—CABLE MTG.—TRANS.         | PT. 117 5711 |
| 29. 5/16—18 X 3/4 SOCKET HD. CAP SCW. | PT. 215 0018 |
| 30. ARM—TRANS. CONTROL SHAFT          | PT. 105 5713 |

385 0007 INSTALLATION

- |                                       |              |
|---------------------------------------|--------------|
| 31. 1/4—28 X 1-1/2 HEX-HEAD CAP SCREW | PT. 215 4052 |
| 32. 1/4" SPLIT LOCKWASHER             | PT. 267 3471 |
| 33. 1/4—28 SQUARE NUT                 | PT. 179 0056 |

CHRYSLER INSTALLATIONS

- |                               |                  |
|-------------------------------|------------------|
| 34. BRACKET—CABLE MTG.—TRANS. | PT. 117 0094     |
| 35. ARM—TRANS. CONTROL SHAFT  | PT. 105 5984     |
| 36. 5/16" FLATWASHER          | PT. 267 3481 (4) |

FORD C-4 & C-6 TRANSMISSIONS

- |                                    |              |
|------------------------------------|--------------|
| 37. BRACKET—CABLE MTG.—C-4 TRANS.  | PT. 117 0037 |
| 38. BRACKET—CABLE MTG.—C-6 TRANS.  | PT. 117 0038 |
| 39. ARM—TRANSMISSION CONTROL SHAFT | PT. 105 0062 |

NOTE: Bagged hardware package also contains parts and instructions for installation of "Safety Ignition Block". Refer to "WARNING" message about vehicles that have steering column lock.

# GM INSTALLATIONS

## CARS WITH FACTORY FLOOR SHIFT ONLY.

RETAIN STOCK CONTROL ARM. CONNECT CABLE END TO STOCK ARM. OPERATION OF SAFETY STEERING COLUMN LOCK, BACK-UP LIGHT SWITCH AND NEUTRAL SAFETY SWITCH IS MAINTAINED.

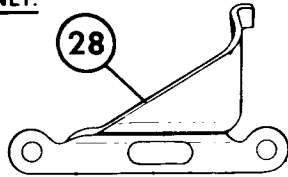

BRACKET  
PT 117 5711

ALL GM INSTALLATIONS USE THIS BRACKET - PT. 117 5711. REFER TO DRAWINGS BELOW FOR METHOD OF FASTENING.

## 400 TURBO-HYDRAMATIC

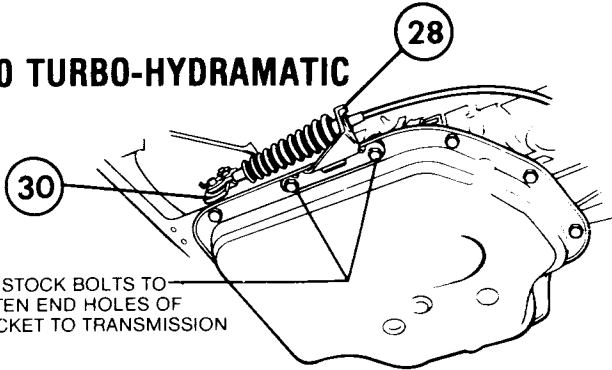

USE STOCK BOLTS TO FASTEN END HOLES OF BRACKET TO TRANSMISSION

## 350 TURBO-HYDRAMATIC

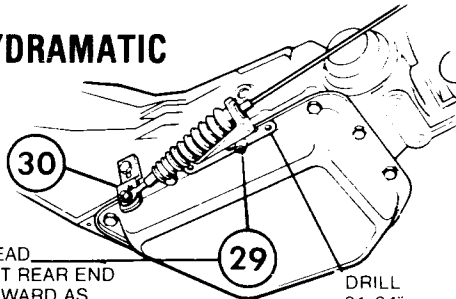

INSTALL BRACKET WITH 5/16-18 x 3/4 SOCKET-HEAD CAP SCREW LOCATED AT REAR END OF SLOT (BRACKET FORWARD AS FAR AS POSSIBLE).

DRILL 21.64" DIAMETER HOLE THRU REAR MTG. HOLE

## 350 TURBO-HYDRAMATIC AND 200 METRIC TURBO HYDRAMATIC

AFTER INSTALLATION IS COMPLETED, DRILL A 21.64" DIAMETER HOLE THROUGH THE TRANSMISSION CASE THROUGH REAR MOUNTING HOLE IN BRACKET (USE BRACKET HOLE AS DRILL GUIDE). FASTEN REAR END OF BRACKET TO TRANSMISSION WITH A SUITABLE 5/16" DIAMETER BOLT, LOCKWASHER AND NUT.

## 200 METRIC TURBO-HYDRAMATIC

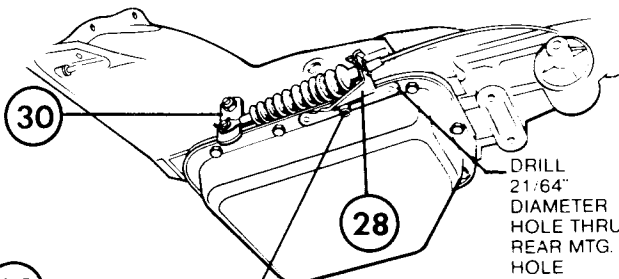

DRILL 21.64" DIAMETER HOLE THRU REAR MTG. HOLE

INSTALL BRACKET WITH 5/16-18x3/4 SOCKET-HEAD CAP SCREW. LOCATE SCREW AT MIDDLE OF SLOT. THE LOCATION CAN BE ADJUSTED WHEN YOU PERFORM "NEUTRAL ALIGNMENT" OPERATION DESCRIBED ON PAGE 4.

# CHRYSLER 904 & 727 TORQUEFLITE

BOLT, LOCKWASHER AND SQUARE NUT ARE FROM STOCK TRANSMISSION ARM

904 TRANSMISSION IS SHOWN. INSTALLATION ON 727 TRANSMISSION IS IDENTICAL

CABLE APPROACHES TRANSMISSION FROM FRONT OF VEHICLE

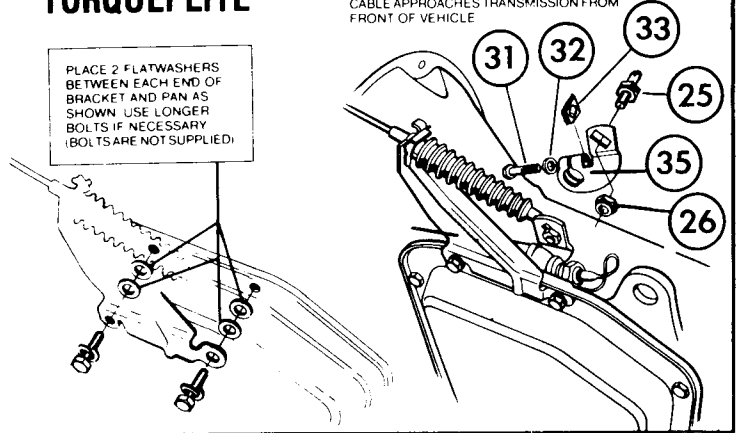

# FORD INSTALLATIONS

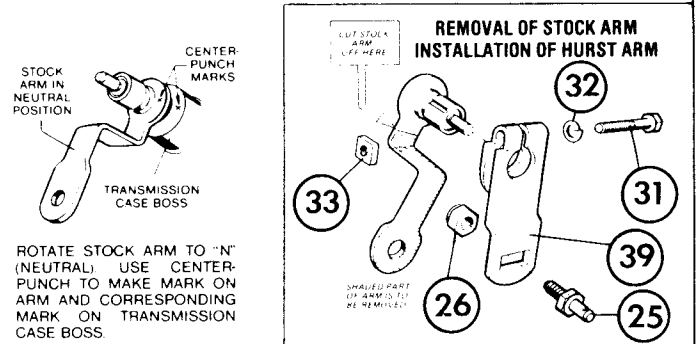

ROTATE STOCK ARM TO "N" (NEUTRAL). USE CENTER-PUNCH TO MAKE MARK ON ARM AND CORRESPONDING MARK ON TRANSMISSION CASE BOSS.

## FORD C-4

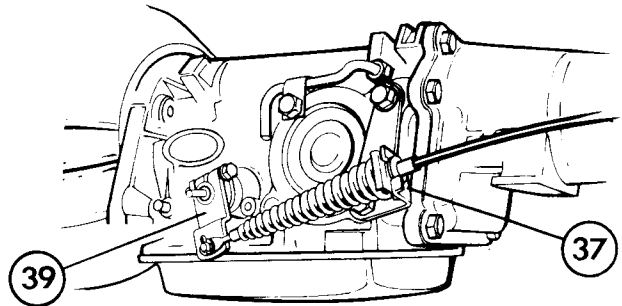

## FORD C-6

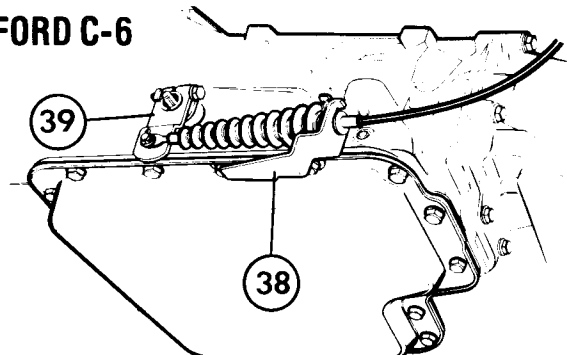

## ALIGNMENT PROCEDURE

1. POSITION ALL SHIFTER STICKS AT "N" (NEUTRAL)
2. POSITION TRANSMISSION ARM AT "N" (NEUTRAL)
3. ADJUST CABLE PIN IN SLOT IN ARM AS SEEN IN BALLOON
4. FASTEN CABLE END ON PIN WITH COTTER PIN

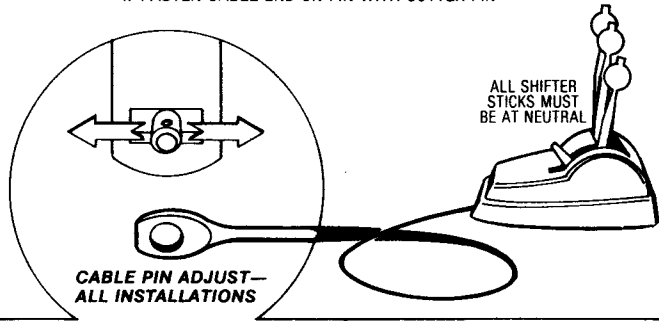

### PATTERNS

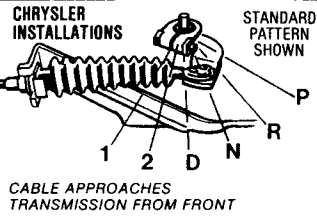
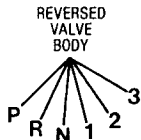
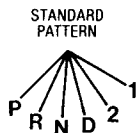

## SHIFTING PATTERN

**IMPORTANT**  
ALL STICKS MUST BE AT THESE POSITIONS DURING ALIGNMENT

● PARK

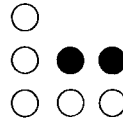

○

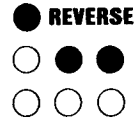

○ NEUTRAL

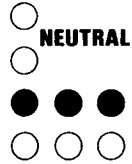

### STANDARD PATTERN

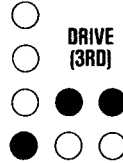

○ DRIVE (3RD)

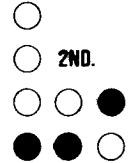

○ 2ND.

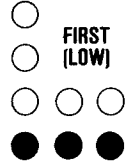

○ FIRST (LOW)

### REVERSED VALVE BODY

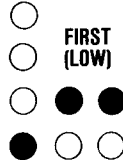

○ FIRST (LOW)

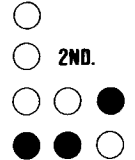

○ 2ND.

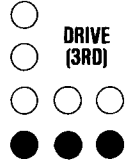

○ DRIVE (3RD)

### INSTALL CONSOLE 1

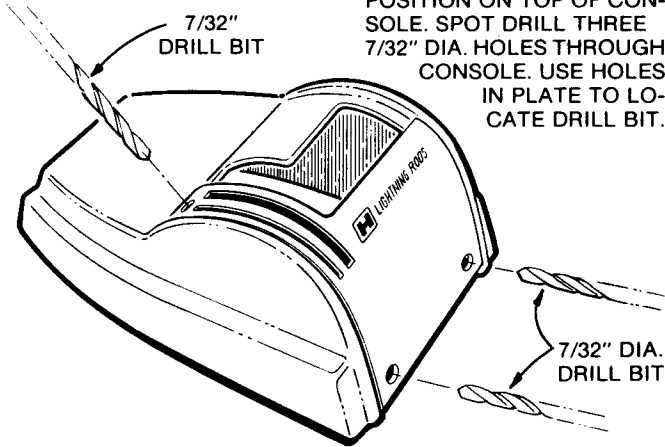

HOLD CONSOLE PLATE IN POSITION ON TOP OF CONSOLE. SPOT DRILL THREE 7/32" DIA. HOLES THROUGH CONSOLE. USE HOLES IN PLATE TO LOCATE DRILL BIT.

### INSTALL CONSOLE 3

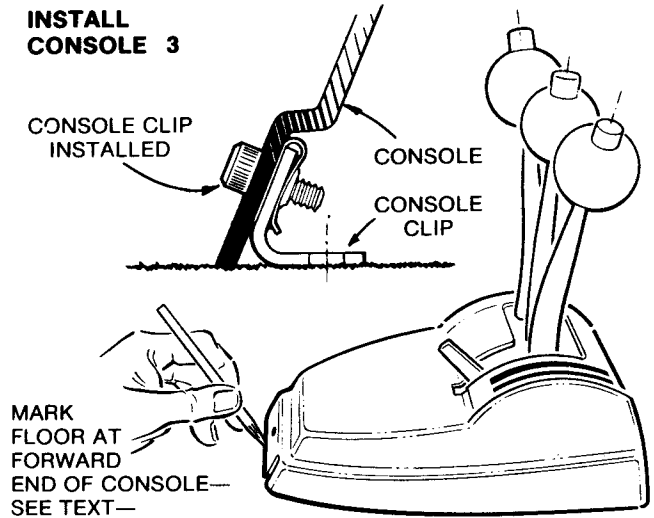

### INSTALL CONSOLE 2

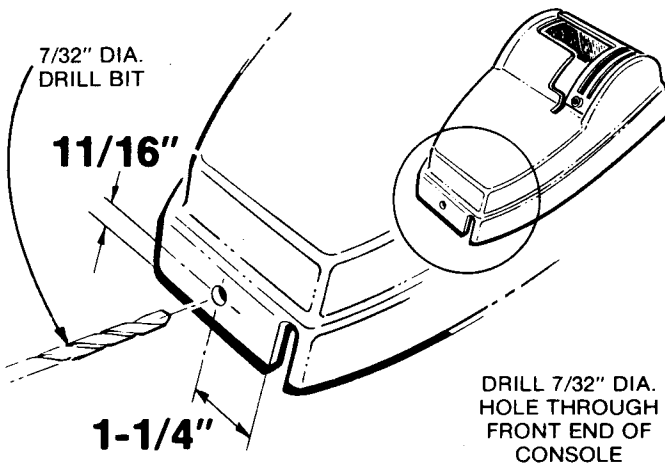

DRILL 7/32" DIA. HOLE THROUGH FRONT END OF CONSOLE

### INSTALL CONSOLE 4

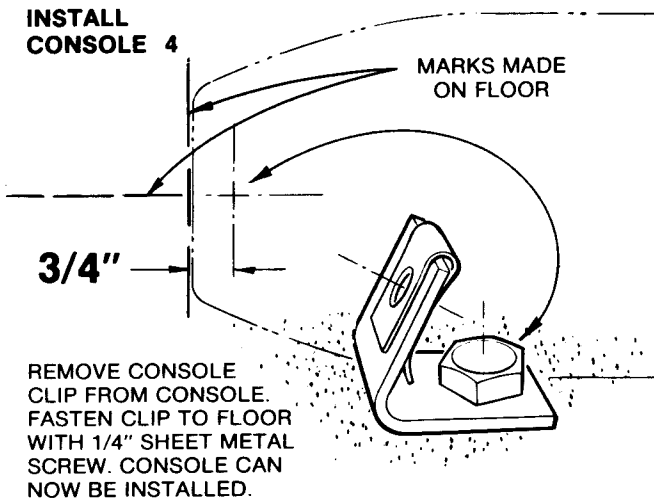

REMOVE CONSOLE CLIP FROM CONSOLE. FASTEN CLIP TO FLOOR WITH 1/4" SHEET METAL SCREW. CONSOLE CAN NOW BE INSTALLED.

**HURST PERFORMANCE, INC.**

91 159 0991 01

PRINTED IN U.S.A.