

373 7919

equipped cars only
IMPORTANT

Spacer block (Pt. 154 7922) is used between stick and center mark on console face shifter.

SHIFTER

STICK

CENTER MARK

SPACER BLOCK

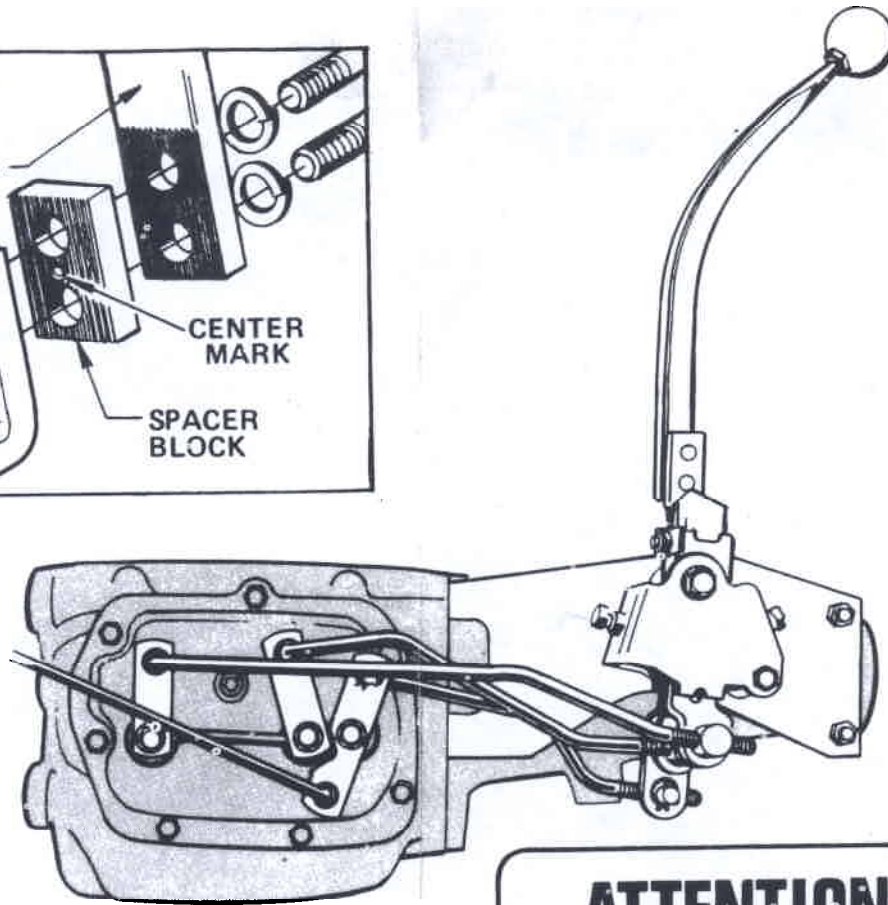

ATTENTION

Due to variations in auto manufacturing tolerances, the transmission rods supplied with this kit may require slight bending to clear obstructions, etc.
 Protect the threads while bending.
BEND RODS COLD! DO NOT APPLY HEAT!

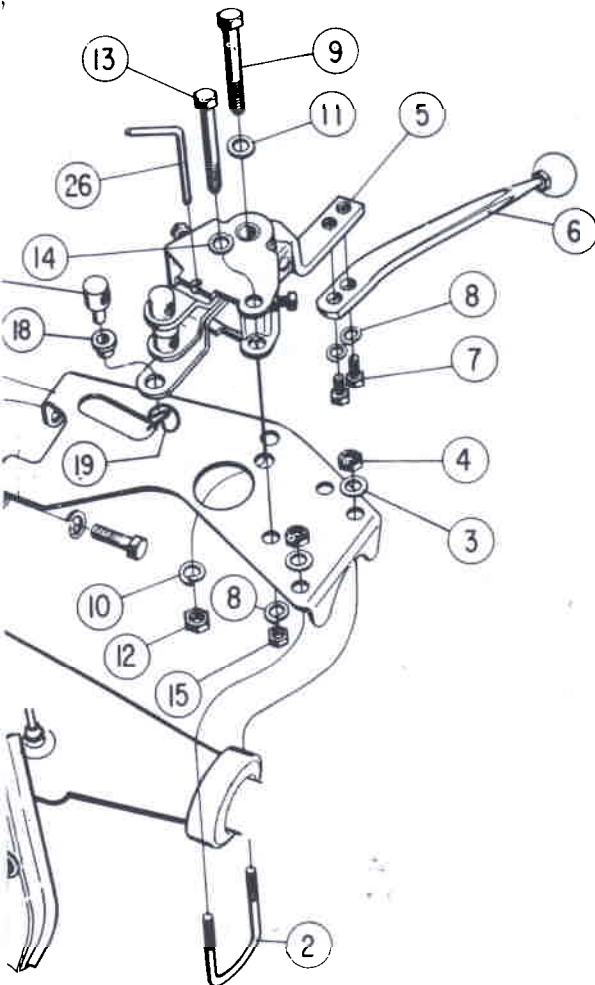

CONTENTS OF KIT

1. MOUNTING BRACKET	Pt. 117 4208
2. "U" CLAMP	Pt. 265 4388
3. 1/4" FLATWASHER	(2)
4. 1/4 - 28 SELF-LOCKING NUT	(2)
5. SHIFTER ASSEMBLY <i>NOT INCLUDED</i>	Pt. 391 7930
6. STICK	Pt. 238 7236
7. 3/8 - 24 x 1 1/4 HEX HEAD CAP SCREW	(2)
8. 3/8" SPLIT LOCKWASHER	(3)
9. 7/16 - 20 x 3 HEX HEAD CAP SCREW	
10. 7/16" FLATWASHER	
11. 7/16" SPLIT LOCKWASHER	
12. 7/16 - 20 HEX NUT	
13. 3/8 - 24 x 3 HEX HEAD CAP SCREW	
14. 3/8" FLATWASHER	
15. 3/8 - 24 HEX NUT	
16. ARM 1st - 2nd	Pt. 105 4293
17. ROD 1st - 2nd	Pt. 213 4187
18. NYLON BUSHING	Pt. 118 1681 (6)
19. SPRING CLIP	Pt. 127 2412 (6)
20. ARM 3rd - 4th	Pt. 105 4294
21. ROD 3rd - 4th	Pt. 213 4188
22. ARM REVERSE	Pt. 105 7923
23. ROD REVERSE	Pt. 213 4335
24. SWITCH ACTIVATING ARM	Pt. 105 4182
25. ROD ADJUSTING BUTTON	Pt. 119 3783 (3)
26. NEUTRAL ALIGNMENT ROD	Pt. 148 1725
27. SPACER BLOCK	Pt. 228 8397*

BAGGED HARDWARE Pt. 154 7922

*Spacer block used in console installation only

**CHECK THE PART NUMBERS STAMPED
ON ALL PARTS RECEIVED WITH KIT WITH
THE PART NUMBERS SPECIFIED**

1. Remove stock linkage, shifter and brackets from transmission. Remove backdrive rod from Reverse arm ONLY.
2. Install mounting bracket by starting the two stock bolts in the forward mounting ears of the bracket. Do not tighten these bolts.
3. Install shifter on mounting bracket. Install the shifter mounting bolts in the shifter after you have maneuvered stick through the opening in the floor tunnel. Fasten the rear of the bracket with the 'U' clamp. Tighten the two bolts that fasten the forward end of the bracket to the transmission. Tighten the two bolts that fasten the shifter to the bracket.
4. Install stick on shifter.

CONSOLE CARS ONLY

Remove center console plate. Install spacer block between stick and shifter. **IMPORTANT: CENTER MARK ON SPACER MUST FACE SHIFTER (toward driver).** Tighten mounting bolts.

6. Insert nylon bushings into holes in levers — refer to assembly view. Align levers with shifter frame and insert neutral alignment rod (Pt. 1725) through notches in frame and holes in levers.
7. Rotate transmission arms backward and forward. The neutral position for each arm can be felt at the mid-position of full travel. Reverse arm must be moved to the end of its travel toward the front of car (dis-engaged position).
8. Adjust positions of button on each rod to permit easy slip-in fit of button into nylon bushing in proper lever. **TRANSMISSION ARMS MUST REMAIN IN NEUTRAL POSITIONS WHILE ALIGNMENT IS ACCOMPLISHED.** Fasten buttons in levers with spring clips.
9. Remove neutral alignment rod. Test shifter. Stick should move freely from side to side at neutral (between 1-2 and 3-4 shifting paths). An increased pull toward the operator should engage the reverse lever. If shifter functions properly, proceed to paragraph 10.

If the stick **CANNOT** be moved freely between 1-2 to 3-4 or reverse path, one or more of the rod button adjustments must be corrected. Move stick forward to 3rd, then back to 4th, then into neutral. Insert neutral alignment rod. If rod **CANNOT** be inserted freely, the 3-4 rod button is incorrectly adjusted. Similar testing of 1-2 shift will prove alignment of 1-2 rod adjustment.

To check reverse rod button adjustment, place stick at neutral. Disconnect reverse rod adjusting button from reverse lever. Grasp rod and push all the way toward front of car. Adjust rod button for easy slip-in fit in bushing. Re-assemble and fasten with spring clip.

10. Adjust shifter stop bolts. Back both bolts out of shifter frame until only a few threads remain engaged. Push stick firmly into 3rd gear and hold. Screw 3rd gear stop bolt in until contact is made. Back bolt out one turn and tighten jam nut. Pull stick firmly back into 4th gear, screw 4th gear stop bolt in until contact is made, then back stop bolt out one turn and tighten jam nut.

11. Install stock backdrive rod in hole provided in the Hurst Reverse arm. Fasten with stock clip.

NOTE — After installation has been completed, check to be sure that the column lock functions properly. If backdrive does not lock column, or if shifter cannot be put into REVERSE adjust backdrive linkage at lower end of column rod.

WARNING

THIS TRANSMISSION DOES NOT HAVE AN INTER-LOCK TO PREVENT ENGAGEMENT OF THE REVERSE GEAR WHEN ANY OF THE FORWARD GEARS ARE ENGAGED. SEVERE DAMAGE TO THE TRANSMISSION WILL RESULT IF THIS SHOULD OCCUR. DOUBLE-CHECK THE LINKAGE BEFORE STARTING THE ENGINE OR MOVING THE CAR. INSERT NEUTRAL ALIGNMENT ROD (Pt. 1725) THROUGH LEVERS AND CHECK POSITIONS OF TRANSMISSION SHIFTING ARMS. 1-2 AND 3-4 TRANSMISSION CONTROL ARMS MUST BE AT NEUTRAL POSITIONS OF THEIR TRAVEL. REVERSE GEAR CONTROL ARM MUST BE AT FORWARD END OF ITS TRAVEL (DIS-ENGAGED).

Console e

IMP

Install spacer
8397) between
shifter — cent
block must fi

